

Modular · intelligent · economical

# TubeScan 100 % Print Inspection



From simple 100 % web monitoring to complex inspection tasks:

# Intelligent print inspection

## Simple and economical 100% print inspection with the TubeScan product series.

Now you can fulfill all of your quality control requirements with a single modular system. TubeScan product series offers 100% web monitoring, detection of missing labels and matrix residues, simple counting of labels to rewinder control, and high resolution 100% print inspection within a workflow.

 **Video**

Print Inspection with TubeScan



Available web widths [mm] and typical applications:

900, 1100, 1400, 1700

See brochure

TubeScan XL

550, 660, 750, 850

330, 430

180, 250

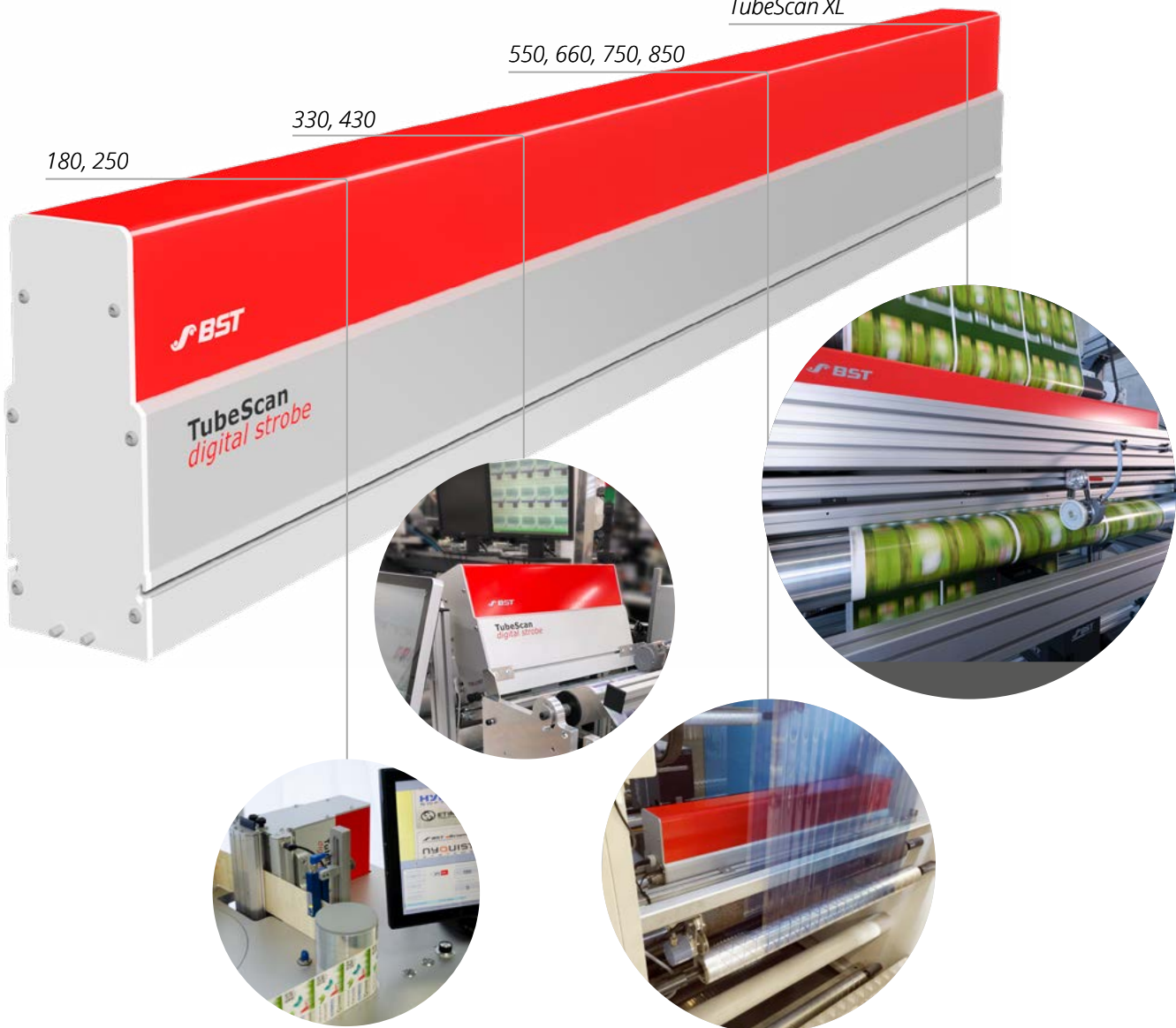

# All you need for your print inspection: TubeScan digital strobe

- » Can take and display up to 30 images per second in live mode – seamless monitoring of every repeat in real time
- » Maximum machine speed up to 500 m / min (1500 ft / min) – depending on the model
- » Superb image quality due to high camera resolution
- » Various camera models available up to 4k resolution
- » 100 % web viewing during make-ready and production
- » Automatic repeat synchronization across the entire speed range of the machine
- » No health risk, less tiring compared to conventional monitoring using strobe lights
- » Fast and easy job setup
- » Interfaces to prepress / ERP systems (customer-specific or standardized such as Hybrid and CERM)
- » Very reliable and stable operation
- » Cost-efficient



*In the split screen view, the reference image is displayed at the top and the current defect is highlighted in the bottom part.*

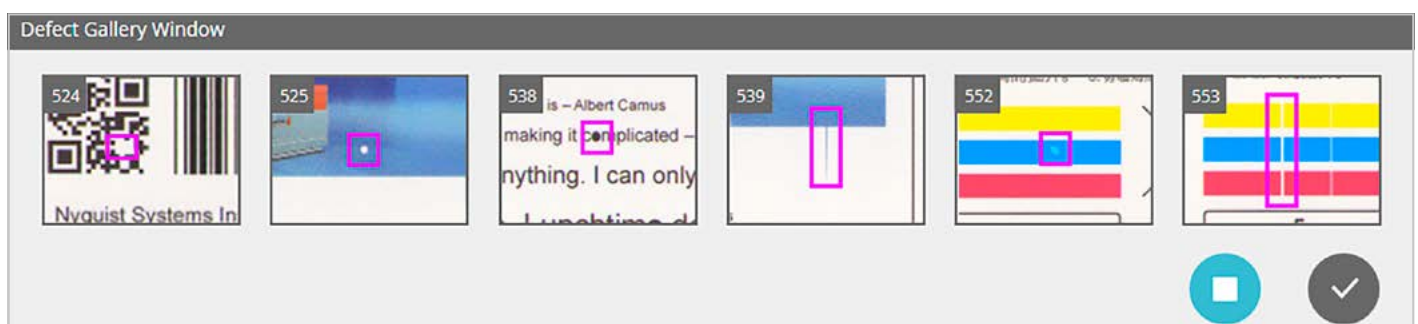

*Defect Gallery: Navigation and quick overview over the last defects.*

The influential factor for print finishing and special effects:

# Control complex printed products with the right lighting

Not every material can be checked well with standard white light. You need the right illumination for special surfaces, such as foil embossing or for luminescent applicati-

ons such as paint, adhesive or silicone applications. Due to the pulsed operation, the power consumption is minimal.

## Bright field illumination for highly reflective materials

 **Video**

Inspection of reflective surfaces



The broad outline of silver foil finishing is highly reflective



Camera image with dark field illumination

With bright field illumination, the foil finishing is clearly visible

- » Choice of dark field or bright field illumination to generate maximum contrast. Matte and slightly glossy surfaces can be checked well in dark field. Bright field illumination is usually more suitable for highly reflective surfaces.

### Typical applications:

- » Cold foil / hot foil applications
- » Holograms
- » Coatings

## UV illumination for luminescent applications

 **Video**

Inspection of luminescent areas



Standard Illumination: The QR code printed with transparent luminescent ink is invisible



With the UV lighting, the QR code is made clearly visible for inspection

- » Inspect luminescent areas such as coatings, adhesives and silicones
- » Inspect security features printed with transparent luminescent ink
- » Switch between standard white light inspection and UV inspection

### Typical applications:

- » Security print
- » Pharma

## Contour light for recognition of elevations

 **Video**

Inspection with contour light

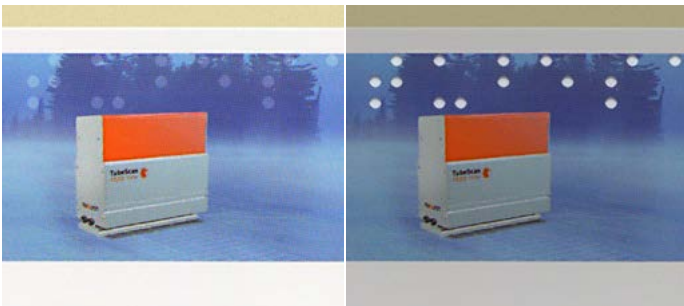

*Braille without contour light:  
Barely visible*

*With contour light, braille writing  
is easy to see*



*Detection of irregularities on  
surfaces ...*

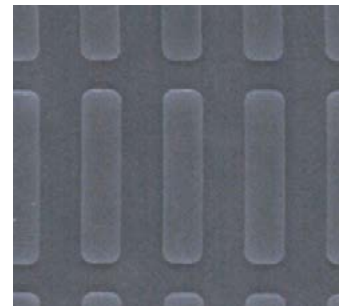

*... or of missing transparent  
labels on transparent or  
opaque liners*

- › The special contour light makes the finest elevations visible for the inspection camera
- › Detect almost invisible missing labels and matrix residues, especially on blank labels
- › Switch between standard white light inspection and contour light inspection

### Typical applications:

- › Clear-on-clear, clear-on-paper (without print)
- › Sleeves / tubes
- › Braille
- › Irregularities on surfaces

## Back light for pinhole detection



*TubeScan reliably detects tiniest pinholes in yogurt lids*

- › Detect tiniest pinholes in aluminum foil and other opaque webs
- › Switch between direct white light illumination for standard print inspection and back light illumination for pinhole detection

### Typical applications:

- › Aluminum lids
- › Blister packs

A modular system that can be expanded at any time:

# Manifold functions for your reliable quality assurance

The image shows a screenshot of the TubeScan software interface, which is used for quality assurance in manufacturing. The interface is divided into several sections, each with a specific function highlighted by a red callout box and arrow:

- Automatic die cutting recognition:** Located at the top center, it shows a digital readout of '2' and '0'.
- Inspection of alphanumeric sequences:** Located at the top right, it shows a digital readout of '1' and '0'.
- Secondary zones and masking for different inspection tasks:** A vertical red bar on the left side of the interface.
- CIE  $L^*a^*b$   $\Delta E$  color monitoring:** A red arrow points to a color calibration chart on the left side of the inspection area.
- Masking of areas to be excluded from inspection:** A red arrow points to a specific area on the inspection target that is masked out.
- Counting reports and errors (order-related, cross-role):** A red arrow points to the 'Total Repeats' field, which displays '3289'.
- 1D and 2D barcode inspection and verification:** A red arrow points to the barcode inspection area on the right side of the interface.

The main inspection area displays two inspection targets side-by-side. Each target includes a ruler, a color calibration chart, and text in multiple languages (English, German, and Chinese). The text includes phrases like 'I cannot teach anybody anything, I can only make them think - Socrates' and 'Time is an illusion. Lunchtime doubly so - Douglas Adams'. Below the text are QR codes and 1D barcodes. The interface also features a control panel at the bottom with various icons for file management, zooming, and other functions.



*Dynamic rollmap to display the errors detected within the currently produced roll*



*The placement control enables precise positioning of a selected defect on the rewinder or doctor machine.*



### Variable Data: Dynamic barcodes and OCR

- » Inspection and decoding of static and dynamic 1D / 2D barcodes with grading
- » Decoding of alphanumeric character strings (OCR)
- » Validation of decoded data against a rule base or with values from a database

# Features overview

## Simple counting and thoroughness

### with TubeScan digital strobe+

100 % print inspection to detect missing labels, matrix residues and coarse defects.

#### Your benefits

- » No time-consuming sensor adjustments
- » Detection of missing labels, coarse print defects and matrix residues
- » Accurate counting of repeats, labels and missing labels for up to 20 lanes – per lane and in total
- » Generation of a 24 volt defect signal to trigger an alarm or marking system
- » Optional placement control module with defect queue for automatic control of a rewinder

## Complex 100 % high-resolution print inspection

### with TubeScan digital strobe++

to detect fine print defects, splashes, register and color deviations, etc.

#### Your benefits – in addition to digital strobe+

- » Detection of fine print defects, register defects and large color deviations, down to approx. Ø 0,2 mm defect size (0,04 mm<sup>2</sup>), depending on the resolution
- » Secondary inspection zones allow defining specific areas at higher or lower inspection tolerances
- » Automatic label contour detection
- » Masking function to ignore defined areas
- » Surface inspection
- » Job save function for repeat orders, incl. master image
- » Real-time display of the detected defects on HD monitor
- » Adjustable sensitivities for various defect classes

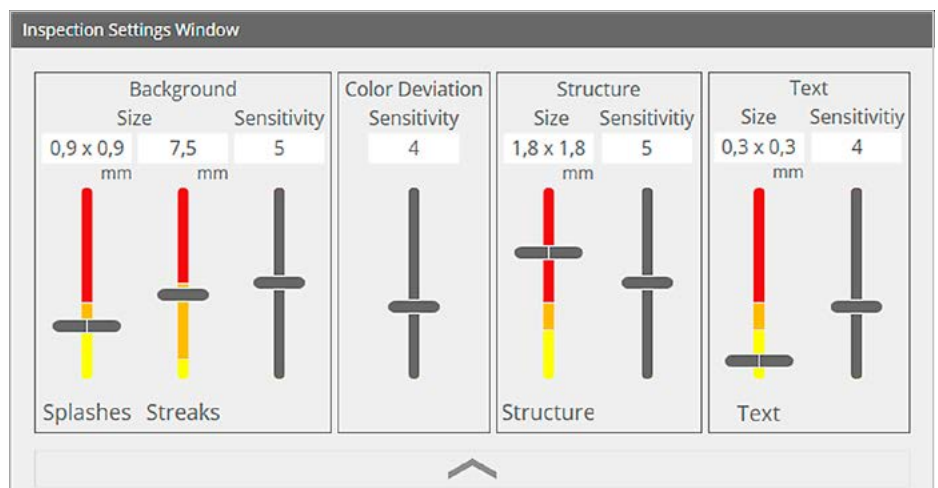

User interface for setting inspection parameters regarding defect size, color sensitivity, register deviation, etc.



## Options

### in addition to TubeScan digital strobe++

- » Relative distance monitoring based on edges or shapes
- » Generation of PDF roll reports
- » Dynamic roll map for the visualization of all defects in the current production roll
- » Snapshot recording and saving of all live-images over a defined period of time
- » Variable data (barcodes, alphanumeric sequences, OCR) and comparison with databases
- » PDF Toolbox
  - a) for master image comparison
  - b) import of inspection zones defined in pre-press, such as masking, die-cutting contours, secondary inspection zones, static or variable 1D / 2D barcodes and alphanumeric sequences
- » Interfaces to prepress / ERP systems (customer-specific or standardized such as Hybrid and CERM)

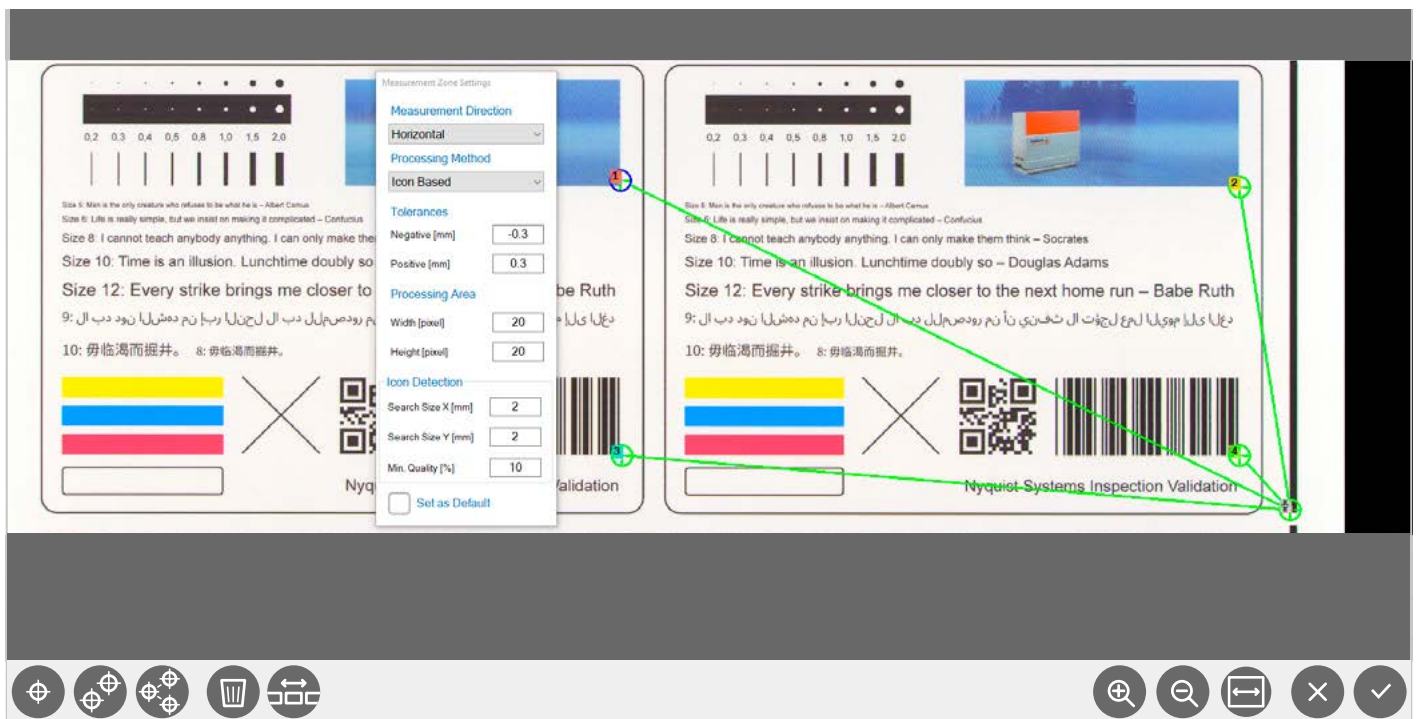

Relative distance monitoring based on edges or shapes

### Available web widths and housing lengths

Model variant digital strobe	180	250	330	430	550	660	760	850	XL: 900 – 1700
Web width in mm	180	250	330	430	550	660	760	850	
Length of housing in mm	310	310	410	510	610	760	840	960	see brochure
Web width in inches	7	10	13	17	22	26	30	34	TubeScan XL
Length of housing in inches	12.2	12.2	16.1	20.1	24.0	29.9	33.0	37.9	

The patented combination:

## TubeScan eagle view

# Web viewing and 100 % inspection

Web viewing systems are a standard in converting and label printing. They are used on almost every printing press to monitor the registration via a greatly enlarged representation of the register marks and the general visualization of particularly relevant print areas such as company logos, colored areas, barcodes, etc.

Web viewing systems, however, are insufficient for 100% print quality monitoring and must be combined with print inspection systems. The disadvantage of in-line 100% inspection systems has been their high initial investment, which many printers have avoided, compromising quality assurance.

The patented TubeScan eagle view is the cost-efficient alternative: several inspection cameras are combined in one system. They provide a detailed viewing, and at the same time 100 % inspection. The intuitive touch screen interface makes setup extremely easy and fast.



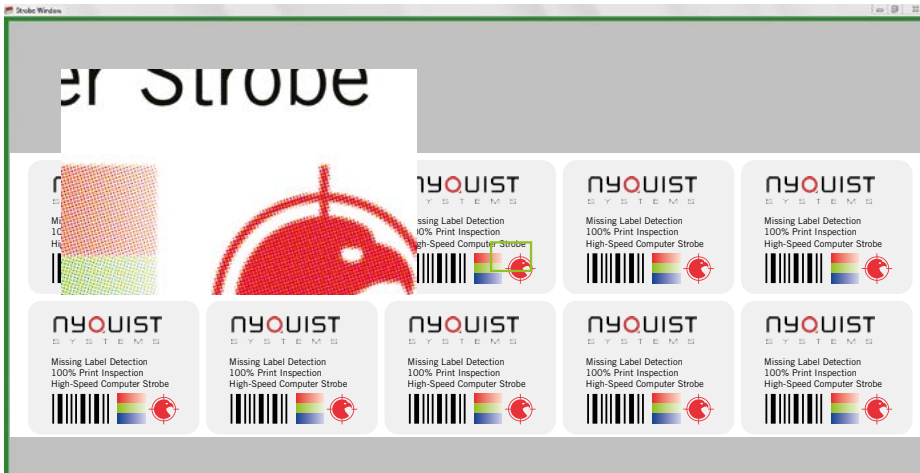

Full web view and detail viewing down to dot matrix level

### Your benefits

- » Cost-efficient combination of 100 % print inspection and detail viewing
- » Detail viewing of critical areas like registration marks, 2D barcodes, picture areas, etc. down to dot level
- » Camera for detail viewing is traversing and can be easily navigated with respect to the displayed print repeat
- » Switchable UV illumination (365 nm)
- » The printing cylinder repeat can be synchronized via an existing gear wheel or print mark sensor. In addition, the synchronization can be carried out purely by software. A connection to external trigger sensors is then not necessary.
- » The register of the reverse side print can be monitored with the optional backlight
- » Small foot print, only 125 mm (5") in web direction
- » Can be combined with all options available for TubeScan digital strobe such as fine print inspection, PDF reporting, dynamic roll map, etc.

### Technical data

Basic functions identical to TubeScan digital strobe

Resolution of detail viewing (traversing camera)	< 30 µm
View area of detail camera	35 mm × 25 mm 1.378" × 0.984" 1600 px × 1200 px
Image rate of detail camera	up to 10 images per second
Maximum speed	250 m / min 820 ft / min
Automatic image synchronization within the repeat	
Picture-in-picture navigation via touch monitor	

### Available web widths and housing lengths

Model variant eagle view	180	250	370	470	550	660
Web width in mm	180	250	370	470	550	660
Length of housing in mm	410	410	510	610	760	840
Web width in inches	7	10	14	18	22	26
Length of housing in inches	16.1	16.1	20.1	24.0	29.9	33.0

# System overview

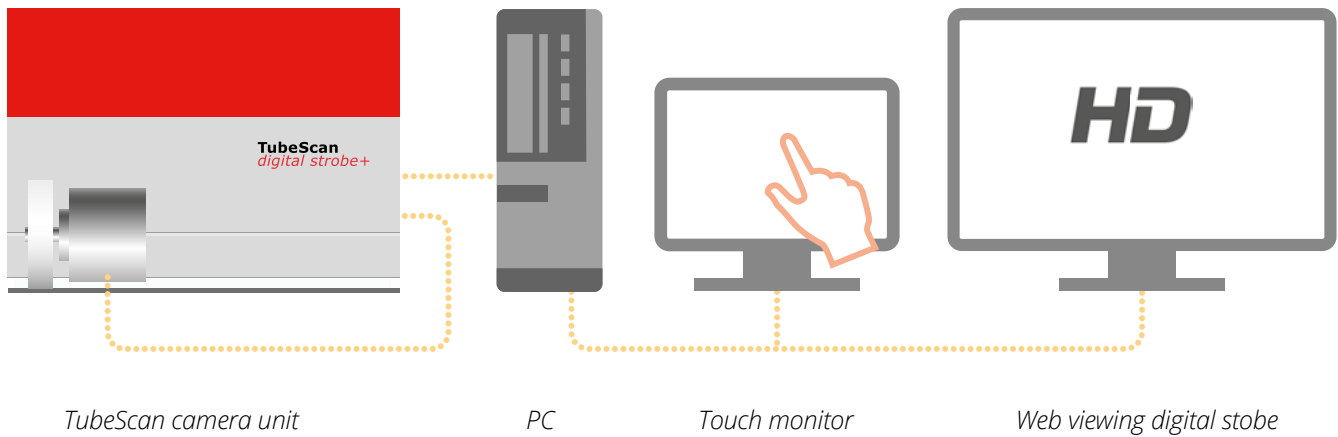

## Backing bar



## Back light illumination

The backing bar can be equipped with integrated back light illumination

### Option A using a light line with high intensity

- » Pinhole detection
- » Buried antennae structures in RFIDs

### Option B using an area light for the detail camera of the TubeScan eagle view

- » Monitoring of the back print register
- » Equalization of textured surfaces such as Tyvek®

## Dimensions

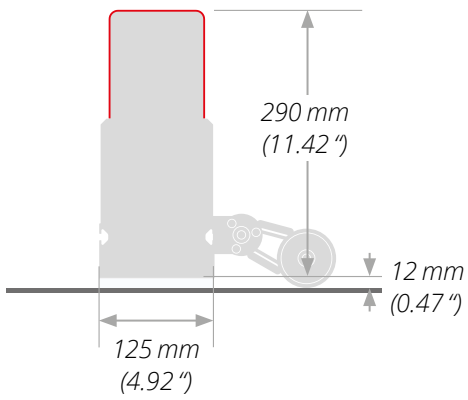

Cross section  
(Width of housing depends on web width)

## Mounting

Cantilever mount,  
for housings up to  
510 mm (20.1")  
of length

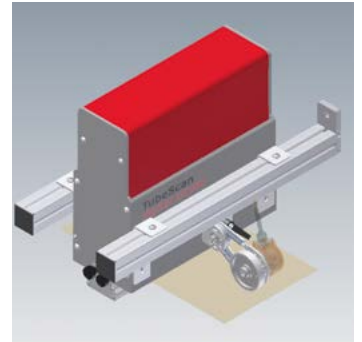

Front  
mounting  
brackets

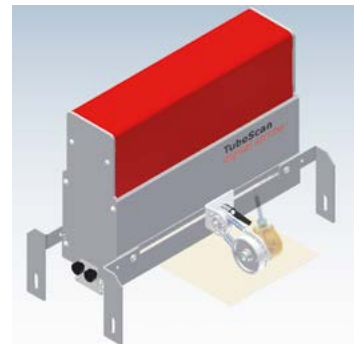

Customized  
double-sided  
mounting

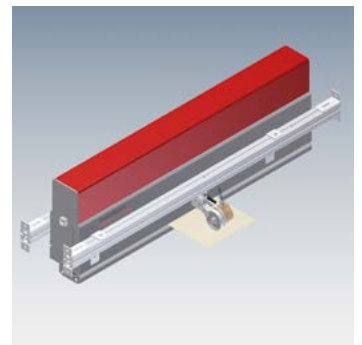

## Technical data for all TubeScan systems

Touch monitor	minimum 15"
HD monitor	minimum 22" (other sizes upon request)
Image rate	up to 30 images per second
Maximum lateral web movement	± 10 mm
Operating temperature	0° - +35° C (+32° - +95° F)
Supply voltage	100 - 240 V, 50 - 60 Hz
Shaft encoder with layon wheel	RS422, channel A+B
10 opto-isolated outputs 24 V, 80 mA max.	Configurable outputs for web-based defect signals, control signals for rewinders, etc..

Smart and economic:

# QLink inspection workflow

## QLink Press

### on the printing press

Software module with local mass storage (NAS), based on TubeScan digital strobe or TubeScan eagle view

### Real-time editor

- » Editing of the roll protocol database during printing
- » Display of the net count in real-time, taking into account the edited roll protocol – per roll or cumulated over the entire production

### Roll management

- » Selection, editing and transfer of the roll protocols within the network

### Local mass storage (NAS)

- » Temporary, local data storage of the roll protocols

## QLink Rewinder

### on the rewinder

Software module, based on TubeScan digital strobe or TubeScan eagle view

- » Processing of all roll protocols in the network
- » Camera-based synchronization and visualization ensures best workflow stability
- » Control of the rewinder
- » The time-consuming and error-prone positioning and adjustment of ultrasonic or contrast sensors is no longer necessary
- » Possibility of skipping future non-relevant defects, which are shown in the rollmap

If there is no roll protocol from the printing press, you can use the TubeScan on the rewinder for missing label detection or even 100 % print inspection – depending on your license package.

The TubeScan on the rewinder substitutes tiring strobe lights, commonly used for web monitoring.

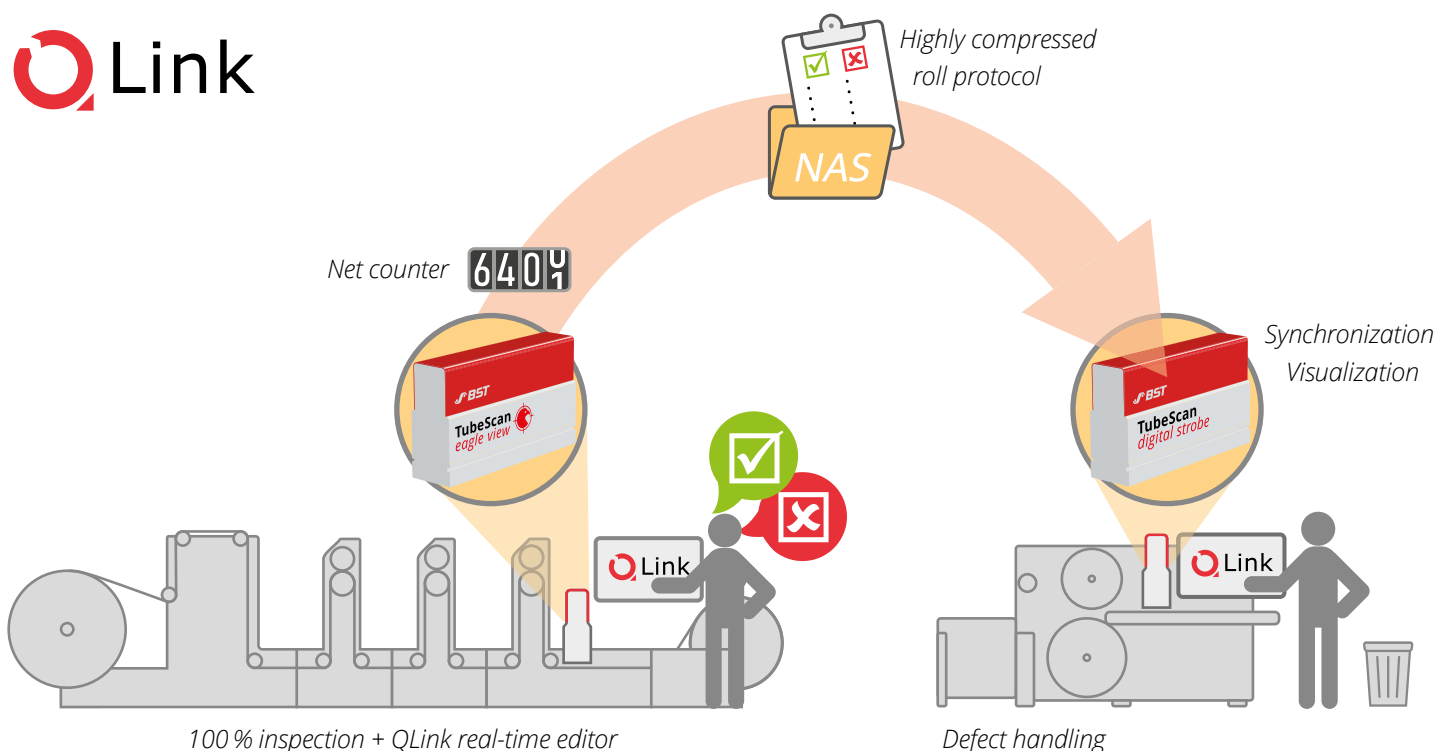

## QLink Editor

### on the PC

The software module QLink Editor is installed on a separate PC (Windows 10). It can either be included in the order or supplied by the customer.

- » Processing of all roll protocols in the network
- » Roll protocols can be visualized and edited for further converting

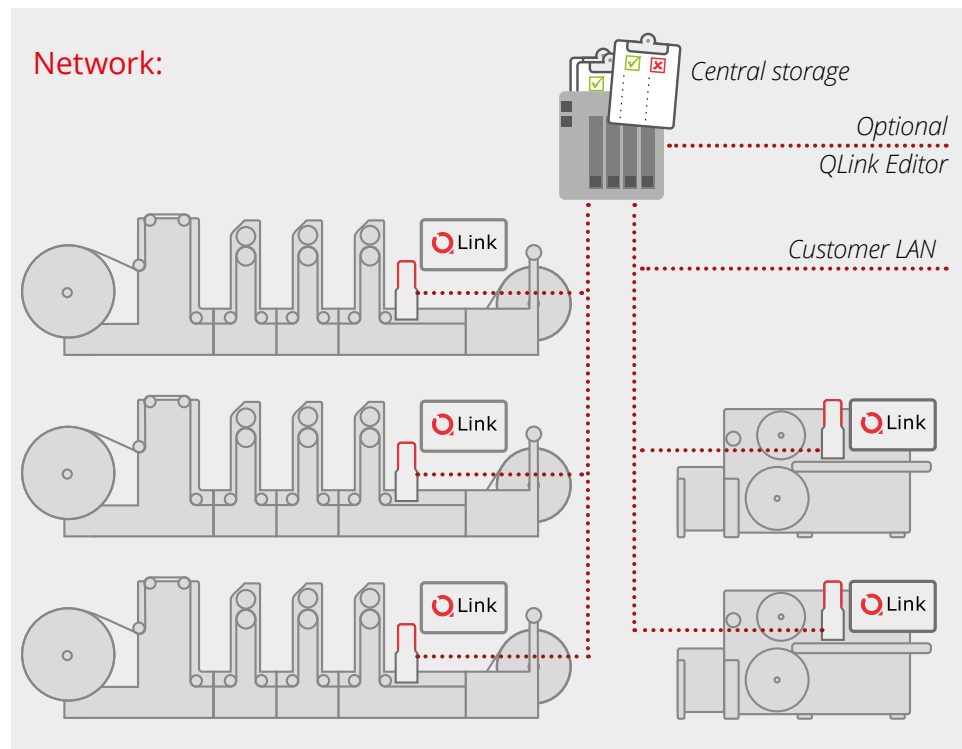

Connection of the modules QLink Press, QLink Rewinder, QLink Editor via LAN.

## Overview of your benefits ...

In comparison to previous inspection workflow systems, the cost for QLink workflow is significantly lower.

### ... on the printing press

- » The QLink real-time editor enables you to evaluate defects already during the printing process. The printer can classify the defects as "not relevant" or "to be fixed" in the converting process.
- » Larger defect areas, such as missing ink, can be defined as waste zones. These can afterwards be removed on the rewinder in one single step.
- » The net count is automatically updated after each editing. No more costly over-production just to make sure there is enough good material.
- » Through innovative compression, the file size of the protocols is as low as 10 % of the usual roll protocols (JPEG / BMP). This saves disk space and expenses, and it will speed up your data transfer.

### ... on the rewinder

- » The camera-based synchronization is easy to set-up and very reliable – in contrast to the sensor-based systems that are commonly used.



BST North America  
4249 Argosy Court  
Madison, WI 53714  
USA

T +1 608 223 0625  
[www.bst.elexis.group](http://www.bst.elexis.group)  
[info@bstna.com](mailto:info@bstna.com)